

Grasso

by Stephen Burks



“Grasso is not fat. Grasso is more than fat. It’s overflowing.”
This is how Stephen Burks sums up his new collection for BD.
An armchair that pursues a visual “ultra-comfort”, and invites you to sit on it. The leather upholstery oozes over the bare iron structure to contrast with the most luxurious touch of the skin. Available in various structure and upholstery colors.

“Grasso no es gordo. Es más que gordo. Es desbordante.”
Así es como resume Stephen Burks su nueva colección para BD. Una butaca que persigue un “ultra-confort” visual, y que invita a sentarse en ella. El tapizado de piel rebosa sobre la estructura de hierro que se deja desnuda para contrastar con el tacto lujoso de la piel. Disponible en varios colores de estructura y tapizados.

bdbarcelona.com/grasso















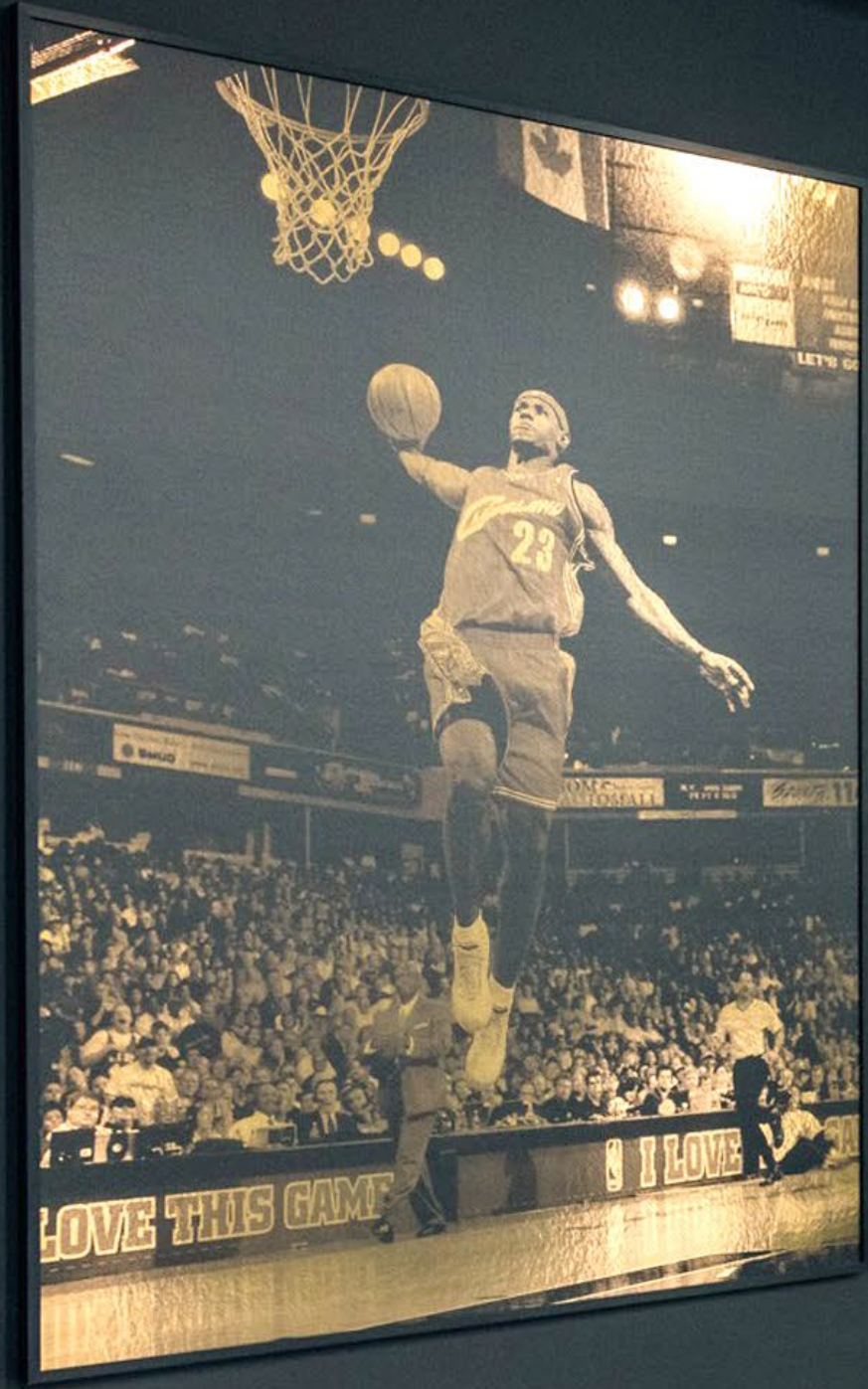

Nike's James LeBron Innovation Centre, Oregon (USA)





The manufacturing of Grasso requires the expertise of a high skilled upholstery team. The backrest and the seat are made from a single piece of leather without any stitching.

La fabricación de Grasso requiere la experiencia de un equipo de tapicería altamente calificado. El respaldo y el asiento están hechos de una sola pieza de cuero sin costuras.

Armchair / Butaca

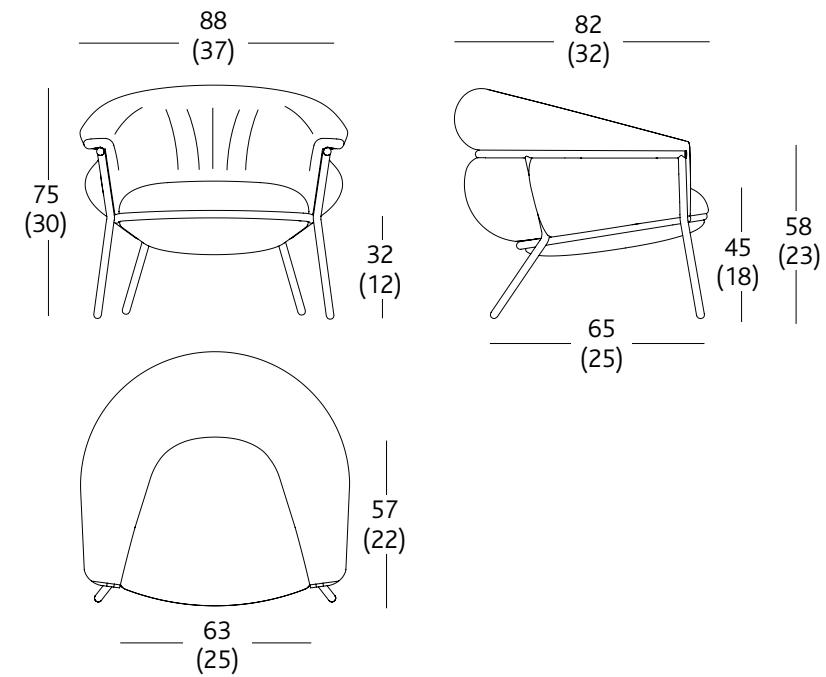

Footstool / Reposapiés

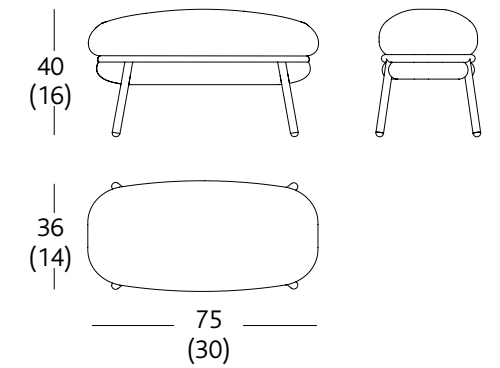

Measurements in cm
(Measurements in inches)



Finishes

Armchair and footstool in tubular steel structure painted in polyester. Upholstered in different leathers and fabrics provided by BD.

Acabados

Butaca y reposapiés en estructura de tubo de acero pintado en poliéster, tapizados con las distintas pieles y tejidos de BD.



2020 ADI-FAD GOLD DELTA AWARD



2019 NYC X DESIGN AWARD



Ramon Turró, 126, 08005 Barcelona, Spain
T +34 93 458 69 09
sales@bdbarcelona.com
bdbarcelona.com

Grasso manufacturing process video / Video del proceso de fabricación de Grasso